

GUARDA-ROUPA 20102-50 Branco/Blanco/White
GUARDA ROPA 20102-96 Freijó/Baunilha - Freijo/Vainilla - Freijo/Vanilla
WARDROBE 20102-97 Freijó - Freijo - Freijo
Comedisa Metálica 20102-98 Freijó/Carbono - Freijo/Carbono
corredora metálica / metallic slide Freijo/Carbon
10 portas - 2 gavetas / 10 puertas - 2 cajones / 10 doors - 2 drawers

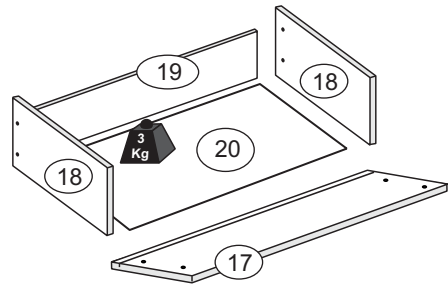

Vista frontal
Vista frontal/Front view

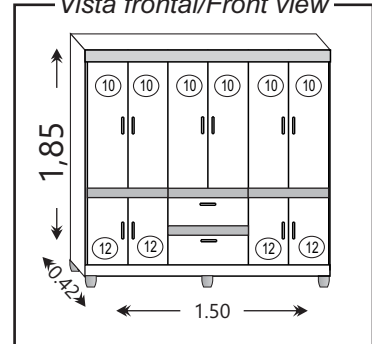

Vista traseira
Vista trasera/Back view

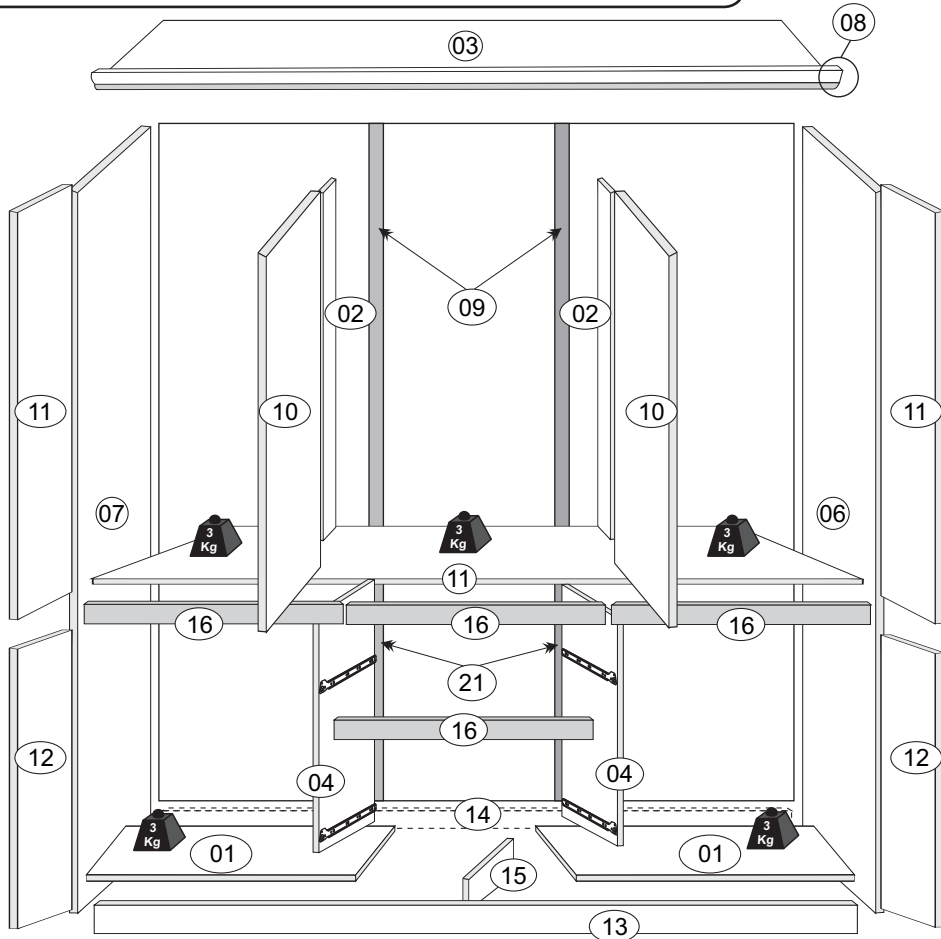
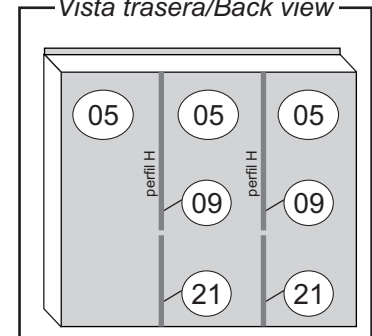

ATENÇÃO/ATENCIÓN/ATTENTION

Ao realizar solicitações de Assistência Técnica, favor seguir as orientações abaixo:
 1º - Informar o MODELO do Ropero (Ex.: 20102-50) / 2º - Informar o CÓDIGO da Peça (Ex.: 10046) / 3º - Informar o CÓDIGO do Revest. (Ex.: 100) / As solicitações de peças deverão ser encaminhado via email: assistencia@araplac.com.br

Quando solicite Asistencia Técnica, por favor siga las orientaciones abajo:
 1º - Informe el MODELO del Ropero (Ej.: 20102-50) / 2º - Informe el CÓDIGO de la Pieza (Ej.: 10046) / 3º - Informe el CÓDIGO del revestimiento de la Pieza (Ej.:100) / Las solicitudes de piezas deberán ser dirigidas via email: assistencia@araplac.com.br

When Technical Assistance is required, please follow the instructions below:
 1º - Inform the MODEL (Ex.:20102-50) / 2º - Inform THE PIECE CODE (Ex:10046) / 3º - Inform THE FINISHING PIECE CODE (Ex: 100). Pieces must be required at assistencia@araplac.com.br

Legenda de Peças / Leyenda de Piezas / Parts Legend

Peça Parte Part	Descrição / Descripción / Description	Medida (mm) Medida (mm) Size (mm)	Qtde. Cant Quantity	Código da PEÇA Código de la pieza Piece code	CÓD.DO REV. DA PEÇA Código de revestimiento de la pieza Piece finishing code				Mat. Prima Mat. Prima Raw material
					Branco Blanco White	Freijó/Baunilha Freijo/Vainilla Freijo/Vanilla	Freijó Freijo Freijo	Freijó/Carbono Freijo/Carbono Freijo/Carbon	
01	Base rodapé / Base rodapié / Baseboard	500x400x12	02	10046	100	1988	1988	1988	MDP
02	Batente / Solapa / Knocker	1040x90x12	02	10052	100	1988	1988	1988	MDP
03	Chapéu / Base superior / Superior base	1476x400x12	01	10044	100	1988	1988	1988	MDP
04	Divisória / Divisoria / Partition	508x395x12	02	10050	100	1988	1988	1988	MDP
05	Fundo / Fondo / Background	488x1590x2,5	03	10060	100	1988	1988	1988	DURATREE
06	Lateral direita / Lateral derecha / Right side panel	1780x400x12	01	10042	100	198	198	198	MDP
07	Lateral esquerda / Lateral izquierda / Left side panel	1780x400x12	01	10043	100	198	198	198	MDP
08	Moldura / Moldura / Frame	1500x100x15	01	10034	100	198	198	198	MDP
09	Coluna maior / Columna mayor / Larger column	1040x40x12	02	10058	100	1988	1988	1988	MDP
10	Porta maior / Puerta mayor / Larger door	1065x245x15	06	10054	117	119889	198	298	MDP
11	Quadro base / Cuadro base / Base frame	1476x400x12	01	10045	100	1988	1988	1988	MDP
12	Porta menor / Puerta menor / Smaller door	450x245x15	04	10056	117	119889	198	298	MDP
13	Rodapé frontal / Rodapié frontal / Frontal baseboard	1476x100x15	01	10047	100	198	198	198	MDP
14	Rodapé traseiro / Rodapié posterior / Back baseboard	1476x100x15	01	10048	99	99	99	99	MDP
15	Trava do Rodapé / Traba del rodapié / Base lock	369x100x15	01	10023	99	99	99	99	MDP
16	Vista frontal / Vista frontal / Front view	484x70x12	04	10051	100	198	198	198	MDP
17	Frente da gaveta / Frente cajón / Front drawer	493x200x15	02	10055	117	119889	198	298	MDP
18	Lateral da gaveta / Lateral del cajón / Drawer side	370x140x12	04	703	100	1988	1988	1988	MDP
19	Contra fundo da gaveta / Contra fondo del cajón / Drawer counterbottom	436x140x12	02	10057	100	1988	1988	1988	MDP
20	Fundo da gaveta / Fondo cajón / Back drawer	380x458x2,5	02	10103	100	1988	1988	1988	DURATREE
21	Coluna menor / Columna menor / Smaller column	508x40x12	02	10059	100	1988	1988	1988	MDP

Kit de Acessórios



Cavilha/pin/wooden dowel - 6,0x30 - 32 Pçs

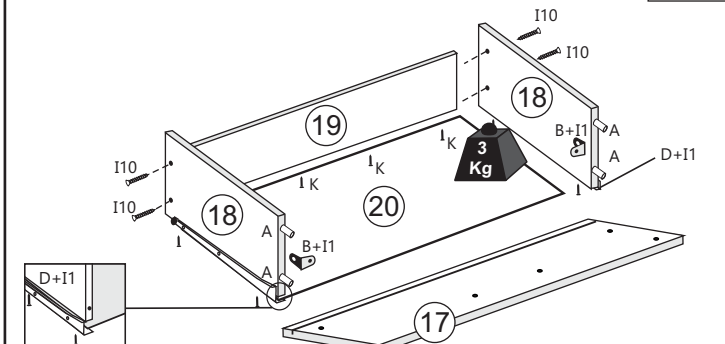
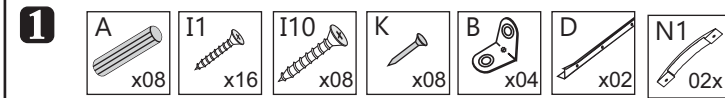
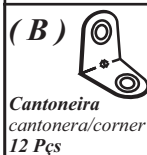
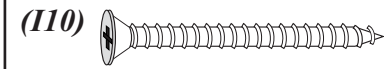
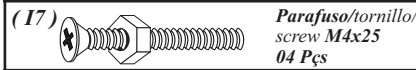

corrediça metálica corredera metálica metallic slide

1º Encaixe as laterais na frente da gaveta com cavilhas, cantoneiras metálicas e cola.
2º Encaixar o fundo da gaveta e contra-fundo da gaveta.
3º Parafusar as laterais no contra fundo com parafuso 3,5x35.
4º Preguar o fundo da gaveta no contra-fundo por baixo com prego 10x10 e os parafusos da corrediça metálica servirão também para parafusar os fundos da gaveta nas laterais.

1º Ajuste las laterales a frente del cajón con las cantoneiras metálicas y el pegamento.
2º Ajuste la parte inferior del cajón y la parte posterior del cajón.
3º Atornille las laterales en la parte posterior con un tornillo 3,5x35.
4º Clave la parte inferior del cajón con el clavo 10x10 y los tornillos de la corrediça metálica también servirán para atornillar los fondos del cajón en los laterales.

1º Fit the sides in front of the drawer with wooden dowels, metallic corners and glue.
2º Fit the bottom of the drawer and back of the drawer.
3º Screw the sides on the back with 3.5x35 screw.
4º Nail the bottom of the drawer to the back bottom under with 10x10 nail and the metallic slide screws will also serve to screw the bottoms of the drawer sides.

2

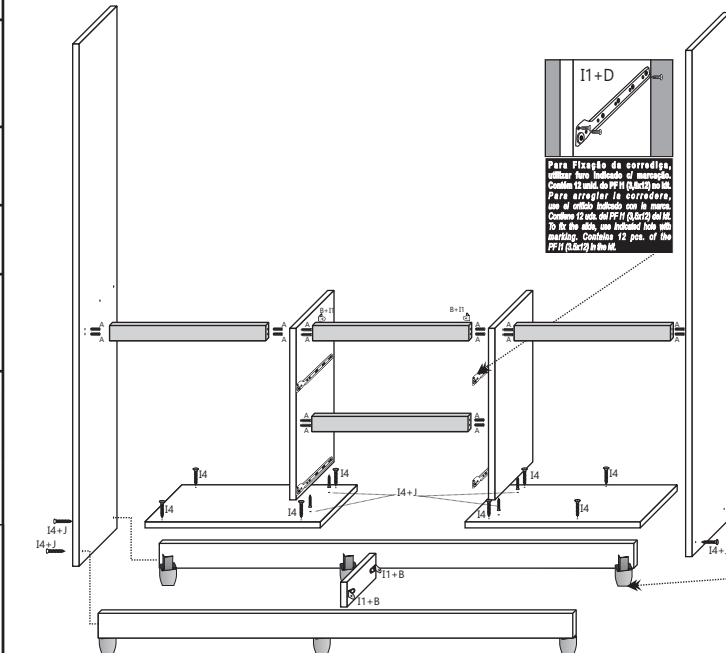

Para fixação de corrediça, utilizar furo indicado de montagem. Como 12 mm. do PFI (G.207) no file. Para arquivar, a corrediça, use o orifício indicado com a mesma medida 12 mm. do PFI (G.207) no file. To fit the slide, use indicated hole with marking. Contains 12 pcs. of the PFI (G.207) in one kit.

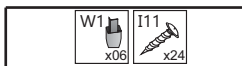
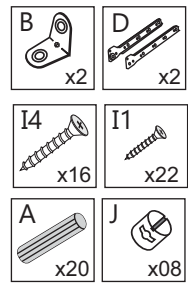

Obs.: Os parafusos utilizados para a fixação dos pés plásticos encontram-se em um sub-kit dentro do kit de acessórios principal.
Note: Los tornillos utilizados para fijar pies de plástico están en un sub-kit dentro del kit de accesorios principal.
Note: The screws used for fixing plastic feet are in a sub-kit inside the main accessory kit.

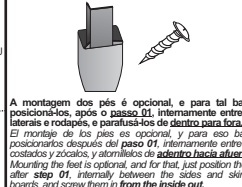

A montagem dos pés é opcional, e para tal basta posicioná-los, após o passo 01, internamente entre as laterais e rodapés, e parafusá-los de dentro para fora. El montaje de los pies es opcional, y para eso basta posicionálos después del paso 01, internamente entre los costados y zócalos, y atornillos de dentro hacia afuera. Mounting the feet is optional, and for that, just position them after step 01, internally between the sides and skirting boards, and screw them in from the inside out.

3

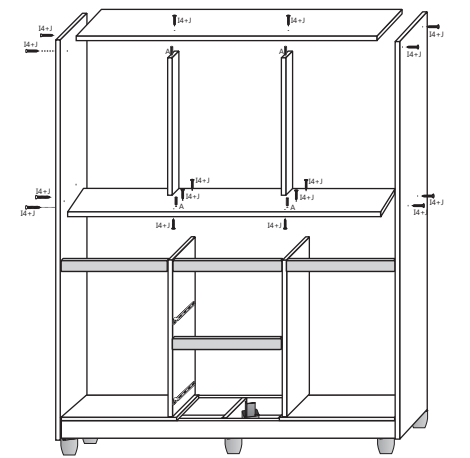
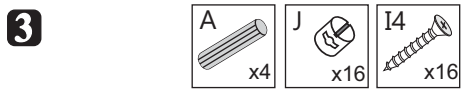

4

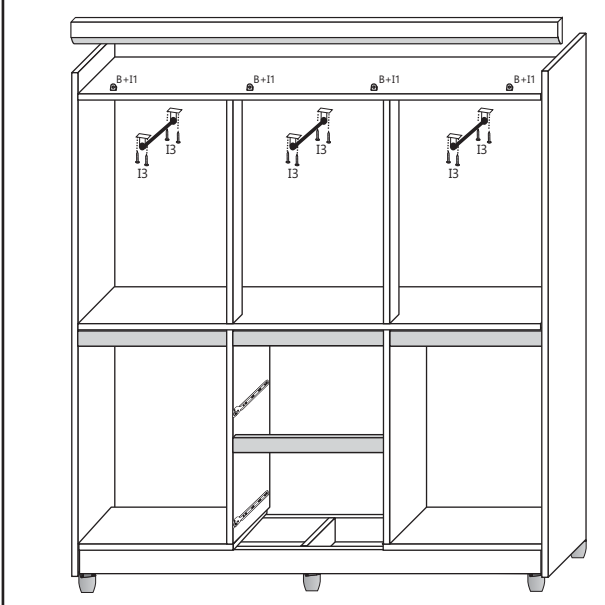
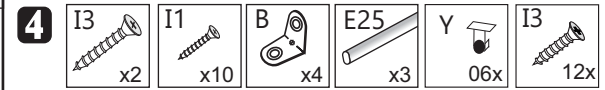

5

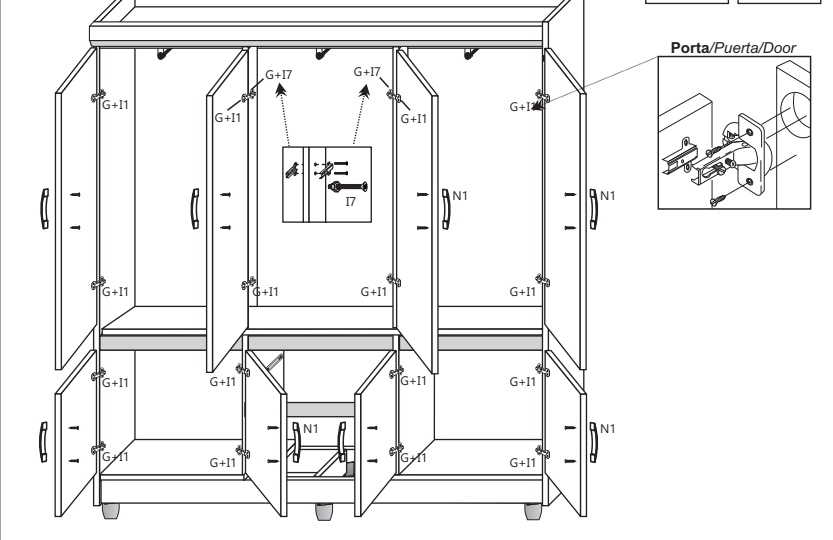

Kit de Espelhos (Opcional) / Kit de Espejos (Opcional) / Mirror Kit (Optional)

- 1- Limpar com pano seco a superfície do local de aplicação (Porta Central)
- 2- Verificar posicionamento correto para aplicação do espelho, conforme desenho abaixo.
- 3- Remover o liner (película protetora) das fitas dupla-face já aplicadas na face traseira de cada espelho.
- 4- Posicionar os espelhos e pressioná-los contra a porta, para garantir o contato total entre o espelho, o adesivo e o painel da porta.
- 5- Ao aplicar incorretamente os espelhos, não é possível removê-los, sujeito a avaria.

- 1- Limpiar la superficie del sitio de aplicación con un paño seco (Puerta Central)
- 2- Verifique el posicionamiento correcto para la aplicación del espejo, de acuerdo con el dibujo a continuación.
- 3- Retire el liner (película protectora) de las cintas de doble cara ya aplicadas en la cara posterior de cada espejo.
- 4- Coloque los espejos y presiónelos contra la puerta, para asegurar un contacto completo entre el espejo, la etiqueta y el panel de la puerta.
- 5- Cuando se colocan incorrectamente los espejos, no es posible quitarlos, sujeto a daño.

- 1- Clean the surface of the application site with a dry cloth (Central Door)
- 2- Check the correct positioning for application of the mirror, according to the drawing below.
- 3- Remove the liner (protective film) from the double-sided tapes already applied to the back face of each mirror.
- 4- Position the mirrors and press them against the door, to ensure full contact between the mirror, the sticker and the door panel.
- 5- When incorrectly applying the mirrors, it is not possible to remove them, subject to damage.

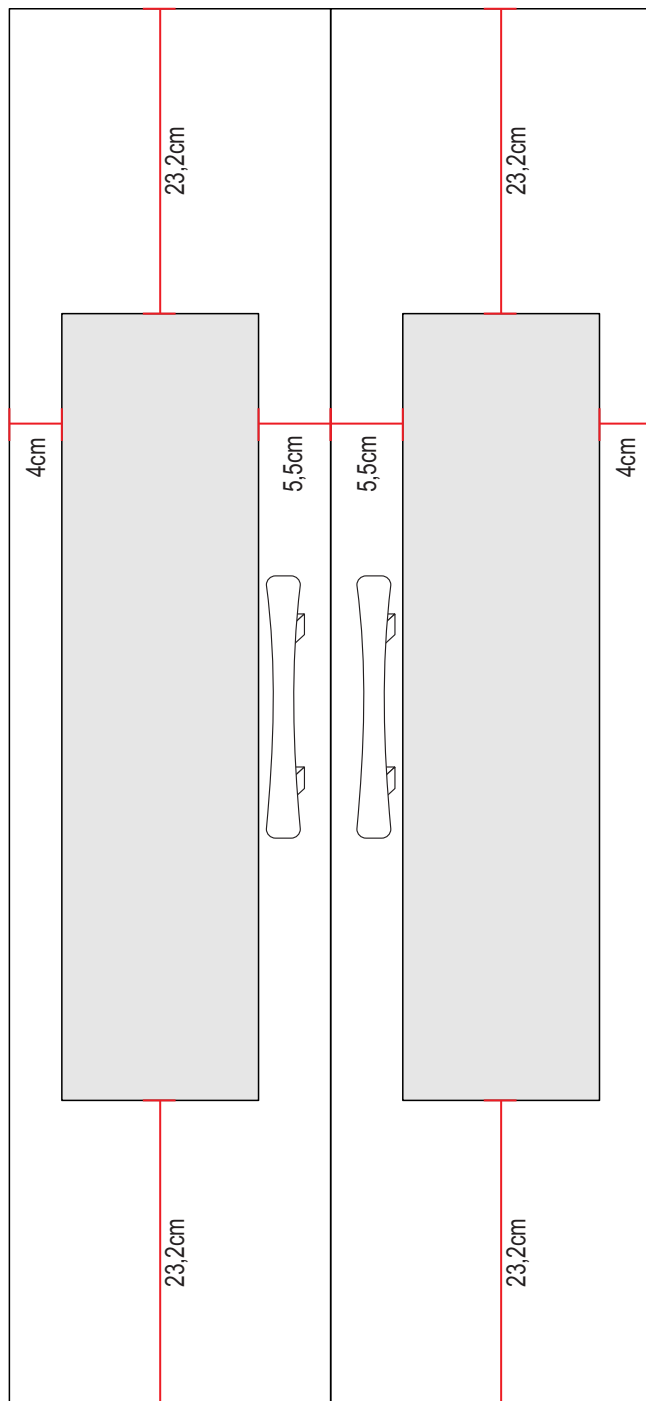

Vista frontal com Espelho Vista frontal con espejo Front view with mirror

