

# GUARDA-ROUPA

GUARDA ROPA  
WARDROBE

Corrediça Metálica

corredora metálica / metallic slide

10 portas - 4 gavetas / 10 puertas - 4 cajones / 10 doors - 4 drawers

2230-96 Freijó/Baunilha - Freijo/Vainilla - Freijo/Vanilla

2230-97 Freijó/Freijo/Freijo

2230-98 Freijó/Carbono - Freijo/Carbono

Freijo/Carbon

2230-396 Pintura Ripado Freijó/Baunilha

Pintura de Listones Freijo/Vainilla

Slatted Painting Freijo/Vanilla



## Vista frontal

Vista frontal/Front view

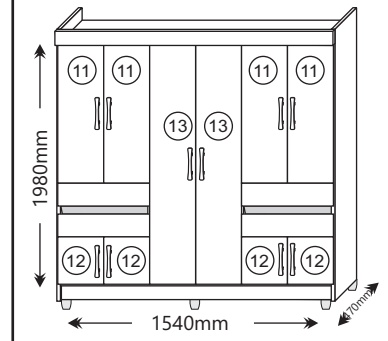

## Vista traseira

Vista traseira/Back view

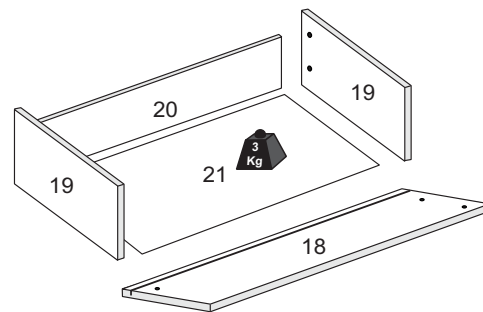
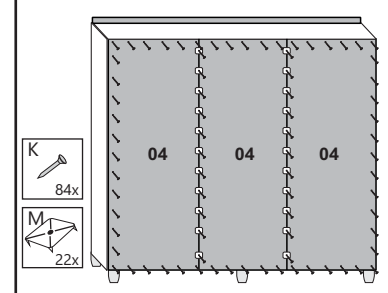

Régua para Medição de Parafusos / Regla de Medición de Tornillo / Screw Measuring Ruler

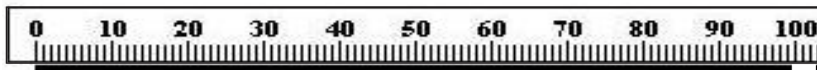
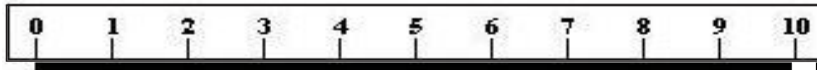

### ATENÇÃO/ATENCIÓN/ATTENTION

Ao realizar solicitações de Assistência Técnica, favor seguir as orientações abaixo:

1° - Informar o MODELO do Roupeiro (Ex.: 2230-97) / 2° - Informar o CÓDIGO da Peça (Ex.: 10588) / 3° - Informar o CÓDIGO do Revest. (Ex.: 1988) / As solicitações de peças deverão ser encaminhado via email: [assistencia@araplac.com.br](mailto:assistencia@araplac.com.br)

Quando solicite Assistência Técnica, por favor siga las orientaciones abajo:

1° - Informe el MODELO del Ropero (Ej.: 2230-97) / 2° - Informe el CÓDIGO de la Pieza (Ej.: 10588) / 3° - Informe el CÓDIGO del revestimiento de la Pieza (Ej.: 1988) / Las solicitudes de piezas deberán ser dirigidas via email: [assistencia@araplac.com.br](mailto:assistencia@araplac.com.br)

When Technical Assistance is required, please follow the instructions below:

1° - Inform the MODEL (Ex.: 2230-97) / 2° - Inform THE PIECE CODE (Ex.: 10588) / 3° - Inform THE FINISHING PIECE CODE (Ex.: 1988). Pieces must be required at [assistencia@araplac.com.br](mailto:assistencia@araplac.com.br)

### Legenda de Peças / Leyenda de Piezas / Parts Legend

| Peça<br>Parte<br>Part | Descrição / Descripción / Description   | Medida (mm)<br>Medida (mm)<br>Size (mm) | Qtde.<br>Cant.<br>Quantity | Código da PEÇA<br>Código de la pieza<br>Piece code | CÓDIGO REV. DA PEÇA<br>Código de revestimiento de la pieza<br>Piece finishing code |                            |  |   | Mat. Prima<br>Mat. Prima<br>Raw material |
|-----------------------|---|---|----------------------------|--|--|----------------------------|--|---|--|
|                       |   |   |                            |  | Freijó/Baunilha<br>Freijo/Vainilla<br>Freijo/Vanilla                               | Freijó<br>Freijo<br>Freijo | Freijó/Carbono<br>Freijo/Carbon<br>Freijo/Carbon | Fri/Bau Ripado<br>Fri/Vai Listones<br>Fri/Van Slatted |  |
| 01                    | Base rodapé / Base rodapié / Baseboard  | 1515x450x12                             | 01                         | 10588  | 1988   | 1988                       | 1988   | 1988  | MDP                                      |
| 02                    | Base prateleira/chapéu / Base repisa/base superior / Shelf base/superior base | 1515x450x12                             | 01                         | 10686  | 1988   | 1988                       | 1988   | 1988  | MDP                                      |
| 03                    | Divisória / Divisoria / Partition   | 1705x450x12                             | 02                         | 10586  | 1988   | 1988                       | 1988   | 1988  | MDP                                      |
| 04                    | Fundo / Fondo / Background  | 512x1730x2,5                            | 03                         | 10601  | 1988   | 1988                       | 1988   | 1988  | DURATREE                                 |
| 05                    | Lateral direita / Lateral derecha / Right side panel                          | 1910x450x12                             | 01                         | 10584  | 198  | 198                        | 198  | 198   | MDP                                      |
| 06                    | Lateral esquerda / Lateral izquierda / Left side panel                        | 1910x450x12                             | 01                         | 10585  | 198  | 198                        | 198  | 198   | MDP                                      |
| 07                    | Moldura / Moldura / Frame   | 1540x85x15                              | 01                         | 10596  | 198  | 198                        | 198  | 198   | MDP                                      |
| 08                    | Prateleira (1 lado) fixa / Repisa (1 lado) fija / Shelf (1 side) fix          | 497x450x12                              | 03                         | 10589  | 1988   | 1988                       | 1988   | 1988  | MDP                                      |
| 09                    | Prateleira (1 lado) móvel / Repisa (1 lado) móvil / Shelf (1 side) mobile     | 497x425x12                              | 01                         | 10591  | 1988   | 1988                       | 1988   | 1988  | MDP                                      |
| 10                    | Prateleira (2 lados) móvel / Repisa (2 lados) móvil / Shelf (2 sides) mobile  | 497x425x12                              | 01                         | 10590  | 1988   | 1988                       | 1988   | 1988  | MDP                                      |
| 11                    | Porta média / Puerta medio / Medium door                                      | 251x889x15                              | 04                         | 10598  | 119889   | 198                        | 298  | 119889  | MDP                                      |
| 12                    | Porta menor / Puerta menor / Smaller door                                     | 251x450x15                              | 04                         | 10597  | 119889   | 198                        | 298  | 119889  | MDP                                      |
| 13                    | Porta central / Puerta central / Central door                                 | 251x1715x15                             | 02                         | 10599  | 119889   | 198                        | 298  | 23197   | MDP                                      |
| 14                    | Rodapé frontal / Rodapié frontal / Frontal baseboard                          | 1515x100x15                             | 01                         | 10592  | 99   | 99                         | 99   | 99  | MDP                                      |
| 15                    | Rodapé traseiro / Rodapié posterior / Back baseboard                          | 1515x100x15                             | 01                         | 10593  | 99   | 99                         | 99   | 99  | MDP                                      |
| 16                    | Trava do Rodapé / Traba del rodapié / Base lock                               | 419x100x15                              | 02                         | 580  | 99   | 99                         | 99   | 99  | MDP                                      |
| 17                    | Vista frontal / Vista frontal / Front view                                    | 497x70x12                               | 02                         | 10594  | 198  | 198                        | 198  | 198   | MDP                                      |
| 18                    | Frente da gaveta / Frente cajón / Front drawer                                | 504x157x15                              | 04                         | 700  | 119889   | 198                        | 298  | 119889  | MDP                                      |
| 19                    | Lateral da gaveta / Lateral del cajón / Drawer side                           | 370x100x12                              | 08                         | 709  | 1988   | 1988                       | 1988   | 1988  | MDP                                      |
| 20                    | Contra fundo da gaveta / Contra fondo del cajón / Drawer counterbottom        | 448x80x12                               | 04                         | 10595  | 1988   | 1988                       | 1988   | 1988  | MDP                                      |
| 21                    | Fundo da gaveta / Fondo cajón / Back drawer                                   | 380x470x2,5                             | 04                         | 10600  | 1988   | 1988                       | 1988   | 1988  | DURATREE                                 |

# Kit de Acessórios

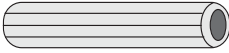
(A)  Cavilha/pin/wooden dowel - 6,0x30 - 28 Pçs

(J)  **Porca cilíndrica**  
tuerca cilíndrica  
cylindrical nut 9x12  
24 Pçs

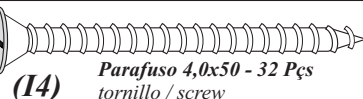
(I4)  **Parafuso 4,0x50** - 32 Pçs  
tornillo / screw

(L)  **Parafuso/tornillo/screw** - 3,5x35 - 16 Pçs

(I1)  **Parafuso**  
tornillo / screw  
3,5x12 - 178 Pçs

(I7)  **Parafuso/tornillo/**  
screw M4x25  
04 Pçs

(K)  **Prego/clavo/nails**  
10x10 - 100 Pçs

(I8)  **Minifix 12x10** - 04 Pçs

(I22)  **Parafuso/tornillo/screw** 3,5x22 - 20 Pçs

(B)  **Cantoneira**  
cantonera/corner  
21 Pçs

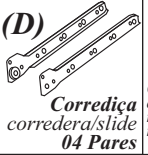
(D)  **Corredora**  
corredera/slide  
04 Pares

(E38)  **Cabideiro metálico**  
ou ABS/perchero  
metalico ou ABS/  
hanger 490mm-02 pçs

(G)  **Dobradiça**  
bisagra/hinge  
22 Pçs

(M)  **Junção de fundo**  
unión de fondo  
background junction  
22 Pçs

(N15)  **Puxador**  
tirador/handle  
10 Pçs

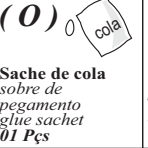
(O)  **Sache de cola**  
sobre de  
pegamento  
glue sachet  
01 Pçs

(P1)  **Sapata**  
Zapata/Shoe  
15x15 - 04 Pçs

(P2)  **Sapata**  
Zapata/Shoe  
15x12 - 04 Pçs

(S1)  **Mini suporte oblongo**  
mini holder oblong  
04 Pçs

(V)  **Suporte de prateleira**  
soporte de repisa  
shelf support  
08 Pçs

(X2)  **Tapa furo**  
Tapa del agujero  
Hole cover  
6 mm - 10 Pçs

(X)  **Tapa furo**  
Tapa del agujero  
Hole cover  
5 mm - 04 Pçs

(I11)  **Parafuso tornillo / screw**  
3,5x14 - 24 Pçs

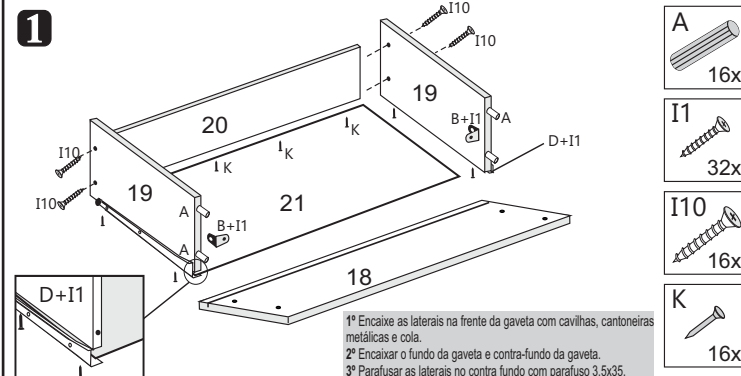

**corredora metálica**  
corredera metálica  
metallic slide

1º Ajuste las laterales a frente del cajón con las cantoneiras metálicas y el pegamento.  
2º Ajuste la parte inferior del cajón y la parte posterior del cajón.  
3º Atornille las laterales en la parte posterior con un tornillo 3,5x35.  
4º Clave la parte inferior del cajón con el clavo 10x10 y los tornillos 10x10 nail and the metallic slide screws will also serve to screw the bottoms of the drawer sides.

1º Encaixe as laterais na frente da gaveta com cavihas, cantoneiras metálicas e cola.  
2º Encaixar o fundo da gaveta e contra-fundo da gaveta.  
3º Parafusar as laterais no contra fundo com parafuso 3,5x35.  
4º Pregor o fundo da gaveta no contra-fundo por baixo com prego 10x10 e os parafusos da corrediça metálica servirão também para parafusar os fundos da gaveta nas laterais.

- A 16x
- I1 32x
- I10 16x
- K 16x
- B 08x
- D 04x

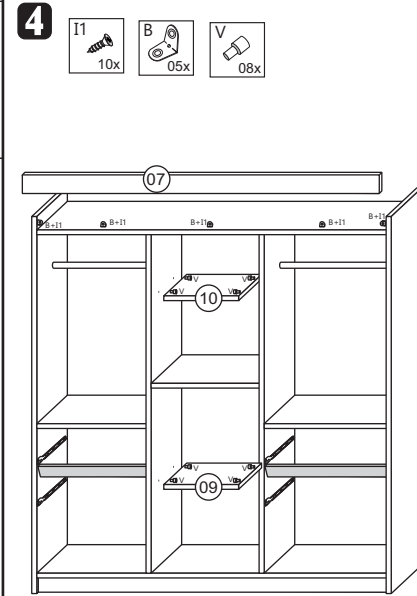

- I1 10x
- B 05x
- V 08x

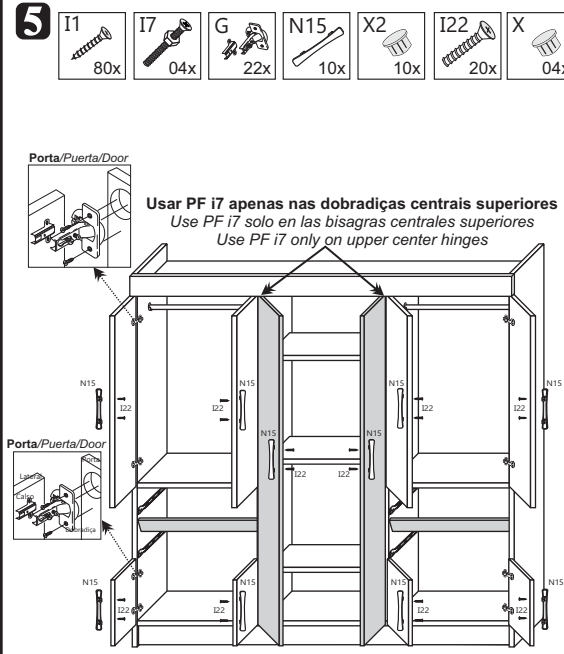

- I1 80x
- I7 04x
- G 22x
- N15 10x
- X2 10x
- I22 20x
- X 04x

Porta/Puerta/Door  
Usar PF I7 apenas nas dobradiças centrais superiores  
Use PF I7 solo en las bisagras centrales superiores  
Use PF I7 only on upper center hinges

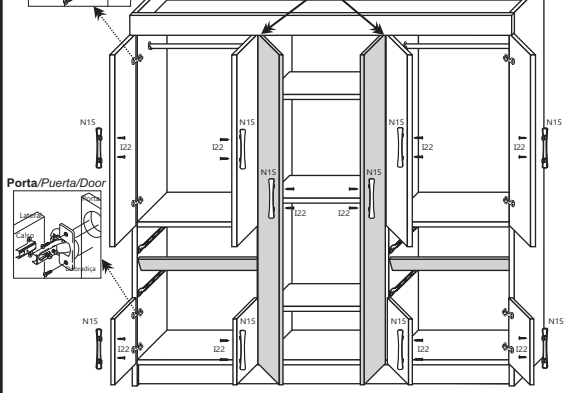

## Kit de Espelhos (Opcional) / Kit de Espejos (Opcional) / Mirror Kit (Optional)

- 1- Limpar com pano seco a superfície do local de aplicação (Porta Central)
- 2- Verificar posicionamento correto para aplicação do espelho, conforme desenho abaixo.
- 3- Remover o liner (película protetora) das fitas dupla-face já aplicadas na face traseira de cada espelho.
- 4- Posicionar os espelhos e pressioná-los contra a porta, para garantir o contato total entre o espelho, o adesivo e o painel da porta.
- 5- Ao aplicar incorretamente os espelhos, não é possível removê-los, sujeito a avaria.

- 1- Limpiar la superficie del sitio de aplicación con un paño seco (Puerta Central)
- 2- Verifique el posicionamiento correcto para la aplicación del espejo, de acuerdo con el dibujo a continuación.
- 3- Retire el liner (película protectora) de las cintas de doble cara ya aplicadas en la cara posterior de cada espejo.
- 4- Coloque los espejos y presiónelos contra la puerta, para asegurar un contacto completo entre el espejo, la etiqueta y el panel de la puerta.
- 5- Cuando se colocan incorrectamente los espejos, no es posible quitarlos, sujeto a daño.

- 1- Clean the surface of the application site with a dry cloth (Central Door)
- 2- Check the correct positioning for application of the mirror, according to the drawing below.
- 3- Remove the liner (protective film) from the double-sided tapes already applied to the back face of each mirror.
- 4- Position the mirrors and press them against the door, to ensure full contact between the mirror, the sticker and the door panel.
- 5- When incorrectly applying the mirrors, it is not possible to remove them, subject to damage.

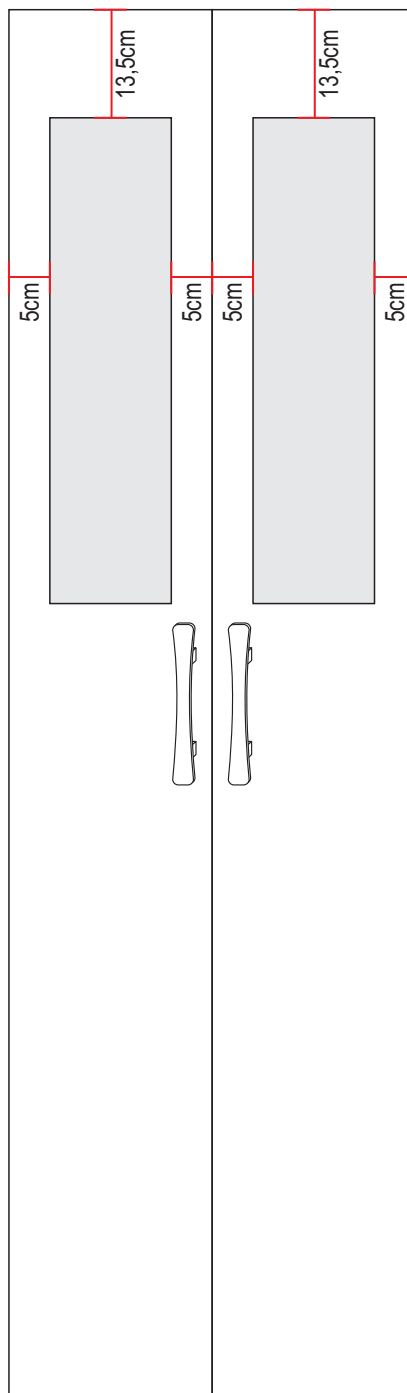

## Vista frontal com Espelho Vista frontal con espejo Front view with mirror

