

# GUARDA-ROUPA

GUARDA ROPA  
WARDROBE

Corrediça Metálica  
corredora metálica / metallic slide

3 portas - 2 gavetas  
3 puertas - 2 cajones  
3 doors - 2 drawers

**CAP2219-96** Freijó/Bauilhã  
Freijo/Vainilla - Freijo/Vanilla

**CAP2219-97** Freijó/Freijo/Freijo

**CAP2219-98** Freijó/Carbono - Freijo/Carbono  
Freijo/Carbon



Ferramentas (não fornecidas)  
Herramientas (no incluidas)  
Tools (not supplied)

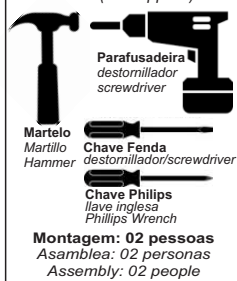

Vista frontal  
Vista frontal/Front view

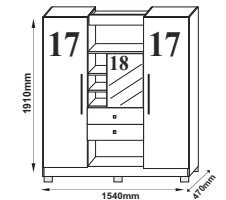

Vista traseira  
Vista trasera/Back view

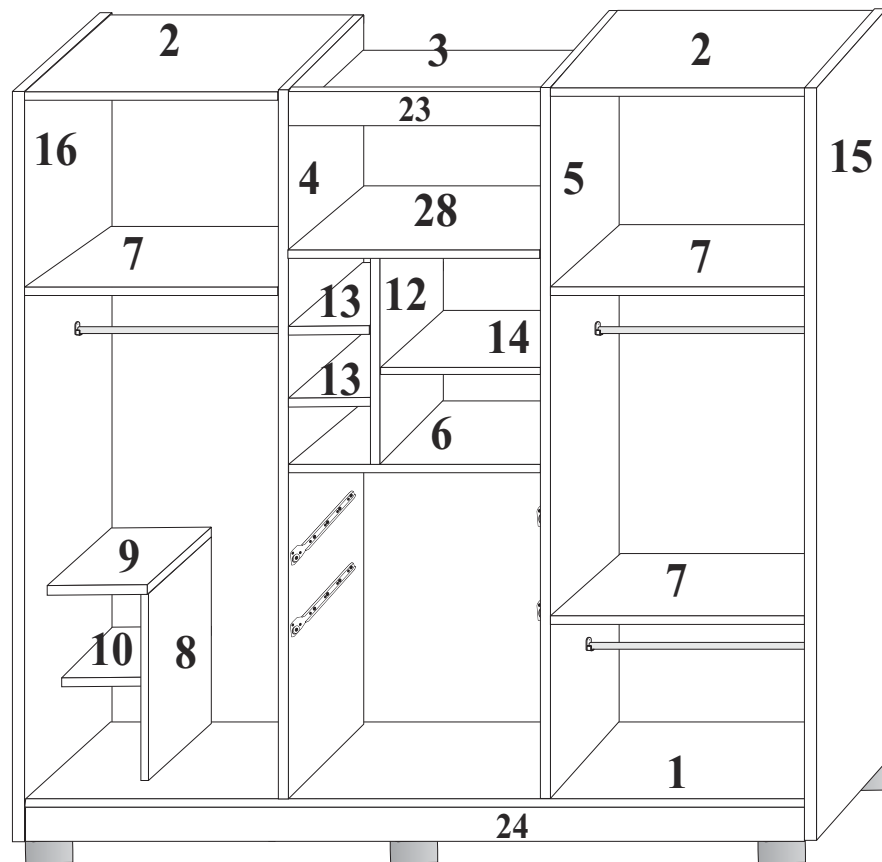
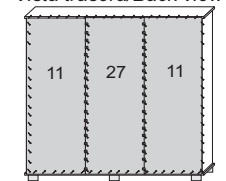

Régua para Medição de Parafusos / Regla de Medición de Tornillo / Screw Measuring Ruler

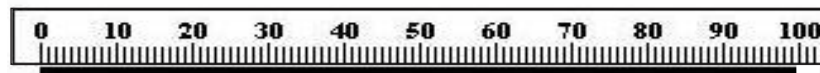
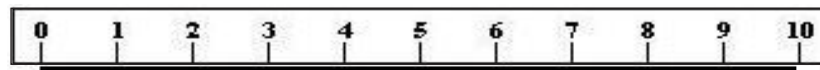

## Kit de Acessório / kit de accesorios / kit of accessories

A	Caviha/Pin/Wooden dowel 6/30	12	K	Prego/Clavo/Nails 10x10	110
B	Cantoneira/Cantenera/Corner 18mm	15	M	Junção de fundo/unión de fondo/background junction 10x10mm	22
D	Corrediça/Corredera/Slide 300mm	02	N35	Puxador/Tirador/Handle - Stub	02
E39	Cabideiro/Perchero/Hanger	03	O	Sache de cola/Sobre de pegamento/Glue sachet 20g	01
G1	Dobradiça/Bisagra/Hinge 26mm	08	S	Suporte oblongo/Soporte oblongo/Holder oblong	06
G2	Calço Mini Slide/Mini cuña deslizante/Mini Slide Wedge (7mm)	06	T5	Tapa furo/Tapa del agujero/Hole cover 5 mm	06
I1	Parafuso/Tornillo/Screw 3,5x12	98	J	Porca cilíndrica/tuerca cilíndrica/cylindrical nut 9x12	50
T6	Tapa furo/Tapa del agujero/Hole cover 6 mm	16	I22	Parafuso/Tornillo/Screw 3,5x25mm (Puxador/Tirador/Handle)	02
I4	Parafuso/Tornillo/Screw 4,0x50	54	I8	Minifix/Minifix/Minifix 12x10	08
I10	Parafuso/Tornillo/Screw 3,5x35	08	T	Porca minifix/Tuerca minifix/Nut minifix 12x10	08
G3	Calço alto/Cuña alta/High wedge 12mm	02	p2	Puxador/Tirador/Handle - Antar	02

## ATENÇÃO/ATENCIÓN/ATTENTION

Ao realizar solicitações de Assistência Técnica, favor seguir as orientações abaixo:  
1º - Informar o MODELO do Roupeiro (Ex.: CAP2219-96) / 2º - Informar o CÓDIGO da Peça (Ex.: 12224) / 3º - Informar o CÓDIGO do Revest. (Ex.: 1998) / As solicitações de peças deverão ser encaminhado via email: asistencia@araplac.com.br  
Cuando solicite Asistencia Técnica, por favor siga las orientaciones abajo:  
1º - Informe el MODELO del Roperio (Ej.: CAP2219-96) / 2º - Informe el CÓDIGO de la Pieza (Ej.: 12224) / 3º - Informe el CÓDIGO del revestimiento de la Pieza (Ej.:1998) / Las solicitudes de piezas deberán ser dirigidas via email: asistencia@araplac.com.br  
When Technical Assistance is required, please follow the instructions below:  
1º - Inform the MODEL (Ex.:CAP2219-96) / 2º - Inform THE PIECE CODE (Ex:12224) / 3º - Inform THE FINISHING PIECE CODE (Ex: 1998). Pieces must be required at asistencia@araplac.com.br

## Legenda de Peças / Leyenda de Piezas / Parts Legend

Peça Parte Part	Descrição / Descripción / Description	Medida (mm) Medida (mm) Size (mm)	Qtde. Cant. Quantity	Código da PEÇA Código de la pieza Piece code	Freijó/Bauilhã Freijo/Vainilla Freijo/Vanilla	Freijó Freijo Freijo	Freijó/Carbono Freijo/Carbono Freijo/Carbon	Mat. Prima Mat. Prima Raw material
					CÓDIGO REV. DA PEÇA Código de revestimiento de la pieza Piece finishing code			
01	Base rodapé / Base rodapié / Baseboard	1516x450x12	01	12224	1988	1988	1988	MDP
02	Chapéu Lateral (menor) / Base superior lateral (menor) / Side superior base (smaller)	450x440x12	02	12241	1988	1988	1988	MDP
03	Chapéu central (maior) / Base superior central (mayor) / Central superior base (larger)	612x375x12	01	12242	1988	1988	1988	MDP
04	Divisória maior (esquerda) / Divisoria mayor (izquierda) / Larger partition (left)	1748x450x12	01	12223	1988	1988	1988	MDP
05	Divisória maior (direita) / Divisoria mayor (derecha) / Larger partition (right)	1748x450x12	01	12245	1988	1988	1988	MDP
06	Prateleira do gaveteiro / Repisa del cajón / Drawer shelf	612x375x12	01	12229	1988	1988	1988	MDP
07	Prateleira lateral (2 lados) / Repisa lateral (2 lados) / Side shelf (2 sides)	440x400x12	03	12227	1988	1988	1988	MDP
08	Divisória da sapateira / Separador de zapatero / shoe rack partition	530x375x12	01	12225	1988	1988	1988	MDP
09	Tampo da sapateira (fita 2 lados) / Zapatero (cinta de 2 lados) / Shoe rack (2-sided top)	75x280x12	01	12226	1988	1988	1988	MDP
10	Prateleira da sapateira / Repisa del zapatero / shoe rack shelf	375x267x12	01	12233	1988	1988	1988	MDP
11	Fundo lateral / Fondo lateral / Side background	1772x455x2,5	02	12248	1988	1988	1988	DURATREE
12	Divisória central / divisoria central / Partition background	530x375x12	01	12296	1988	1988	1988	MDP
13	Prateleira móvel menor / Repisa móvil menor / Smaller mobile shelf	375x205x12	02	12232	1988	1988	1988	MDP
14	Prateleira central / Repisa central / Central Shelf	395x375x12	01	12231	1988	1988	1988	MDP
15	Lateral direita / Lateral derecha / Right side panel	1860x450x12	01	12220	198	198	198	MDP
16	Lateral esquerda / Lateral izquierda / Left side panel	1860x450x12	01	12222	198	198	198	MDP
17	Porta lateral / Puerta lateral / Side door	1760x450x15	02	12239	119889	1988	298	MDP
18	Porta central / Puerta central / Central door	540x410x15	01	12238	198	198	198	MDP
19	Frente da gaveta / Frente cajón / Front drawer	604x200x15	02	12237	119889	198	298	MDP
20	Lateral da gaveta / Lateral del cajón / Drawer side	370x140x12	04	703	1988	1988	1988	MDP
21	Contra fundo da gaveta / Contra fondo del cajón / Drawer counterbottom	564x140x12	02	12244	1988	1988	1988	MDP
22	Fundo da gaveta / Fondo cajón / Back drawer	588x380x2,5	02	12247	1988	1988	1988	DURATREE
23	Moldura / Moldura / Frame	612x100x15	01	12234	198	198	198	MDP
24	Rodapé frontal / Rodapié frontal / Frontal baseboard	1516x100x15	01	12235	198	198	198	MDP
25	Rodapé traseiro / Rodapié posterior / Back baseboard	1516x100x15	01	12236	99	99	99	MDP
26	Trava do Rodapé / Traba del rodapié / Base lock	418x100x15	02	12214	99	99	99	MDP
27	Fundo central / Fondo central / Central background	1772x623x2,5	01	12296	1988	1988	1988	DURATREE
28	Prateleira da colmeia / Repisa de la colmena / Honeycomb shelf	612x375x12	01	12228	1988	1988	1988	MDP

- 1 Montar os rodapés e travas, e inserir os pés com PF 3,5x14.**  
 Montar los rodapiés y trabas, y introducir los pies con PF 3,5x14.  
 Assemble the baseboards and locks, and insert the feet with PF 3.5x14.

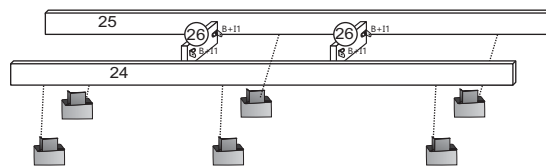

- 2 Fixar as bases nos rodapés.**  
 Fijar las bases en los rodapiés.  
 Fix the bases on the baseboards.

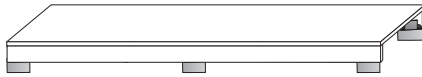

- 3 Inserir as corredeiras nas divisórias.**  
 Inserte las correderas en las divisorias.  
 Insert the slides in the partitions.

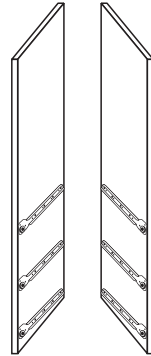

- 4 Fixar as divisórias com minifix.**  
 Arreglar las divisorias con minifix.  
 Fix partitions with minifix.

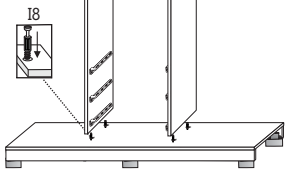

- 5 Fixar a prateleira do gaveteiro nas divisórias com PF 4,0x50.**  
 Fijar la repisa del cajón en las divisorias con PF 4,0x50.  
 Fix the drawer shelf in the partitions with PF 4.0x50.

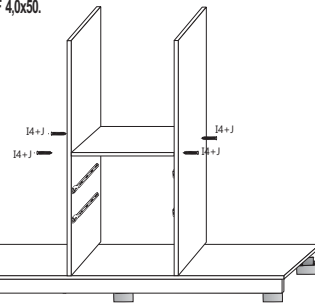

- 6 Fixar a lateral direita e prateleiras com PF 4,0x50.**  
 Fijar la lateral derecha y repisas con PF 4,0x50.  
 Fix the right side and shelves with PF 4.0x50.

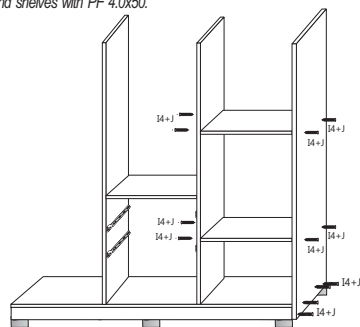

- 7 Fixar as laterais no rodapé e maleiro com PF 4,0x50.**  
 Fijar las laterales en los rodapié y maletero con PF 4,0x50.  
 Fix the sides to the baseboard and luggage space with PF 4.0x50.

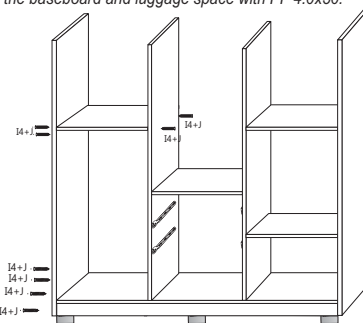

- 8 Fixar a prateleira na divisória central.**  
 Fijar la repisa en la divisoria central.  
 Fix the shelf to the central partition.

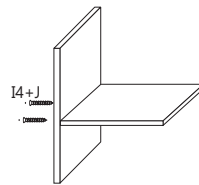

- 9 Fixar divisória, tampo e prateleira da colmeia.**  
 Fijar la divisoria, tampo superior y repisa del colmena.  
 Fix partition, top and honeycomb shelf.

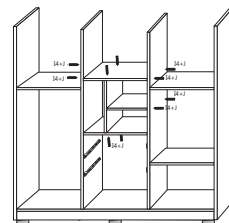

- 10 Fixar os chapéus.**  
 Fijar las bases superior.  
 Fix the superior base.

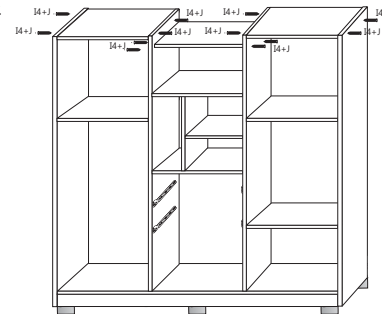

- 11 Fixar a moldura com cantoneira e PF 3,5x12.**  
 Fijar la moldura con cantonera e PF 3,5x12.  
 Fix the frame with corner and PF 3.5x12.

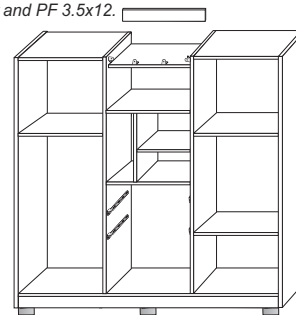

- 12 Fixar a divisória e o tampo da sapateira.**  
 Fijar la divisoria y la parte superior del zapatero.  
 Fix the partition and the top of the shoe rack.

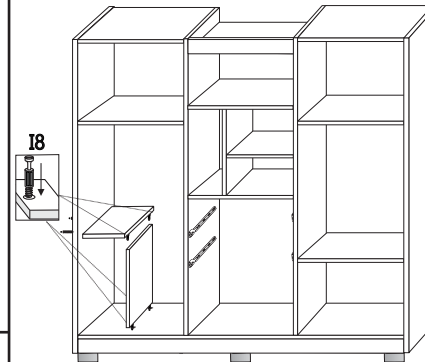

- 13 Fixar os cabideiros. Inserir a prateleira móvel com pino plástico.**  
 Arreglar los percheros. Inserte la repisa móvil con pasador de plástico.  
 Fix the hangers. Insert the mobile shelf with plastic pin.

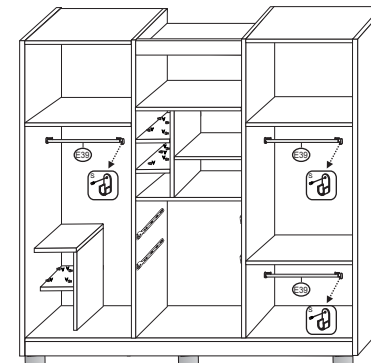

- 14 Inserir as portas com dobradiças.**  
 Inserte las puertas con bisagras.  
 Insert the doors with hinges.

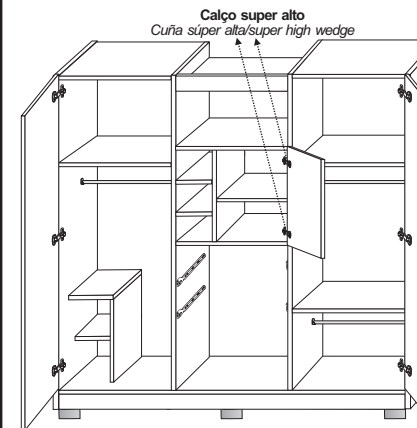

- 15 Pregar os fundos.**  
 Clave los fondos.  
 Nail the back.

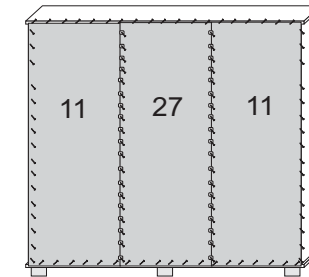

- 16 Inserir os puxadores com PF 3,5x25.**  
 Fixar o espelho na porta central com fita dupla face.  
 Introducir los tiradores con PF 3,5x25.  
 Fijar el espejo a la puerta central con cinta de doble cara.  
 Insert the handles with PF 3.5x25.  
 Fix the mirror to the central door with double-sided tape.

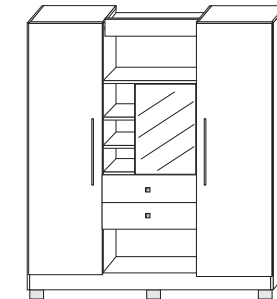

- 17 Montagem das gavetas**  
 Montaje de cajones  
 Assembly of drawers

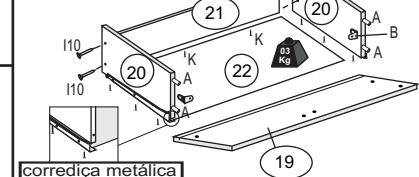

corredeira metálica  
 corredera metálica  
 metallic slide

1º Encaixe as laterais na frente da gaveta com cavilhas, cantoneiras metálicas e cola.

2º Encaixar o fundo da gaveta e contra-fundo da gaveta.

3º Parafusar as laterais no contra fundo com parafuso 3,5x35.

4º Pregar o fundo da gaveta no contra-fundo por baixo com prego 10x10 e os parafusos da corredeira metálica servirão também para parafusar os fundos da gaveta nas laterais.

1º Ajuste las laterales a frente del cajón con las cantoneras metálicas y el pegamento.

2º Ajuste la parte inferior del cajón y la parte posterior del cajón.

3º Atornille las laterales en la parte posterior con un tornillo 3,5x35.

4º Clave la parte inferior del cajón con el clavo 10x10 y los tornillos de la corredera metálica también servirán para atornillar los fondos del cajón en los laterales.

1º Fit the sides in front of the drawer with wooden dowels, metallic corners and glue.

2º Fit the bottom of the drawer and back of the drawer.

3º Screw the sides on the back with 3.5x35 screw.

4º Nail the bottom of the drawer to the back bottom under with 10x10 nail and the metallic slide screws will also serve to screw the bottoms of the drawer sides.